

# ZS500

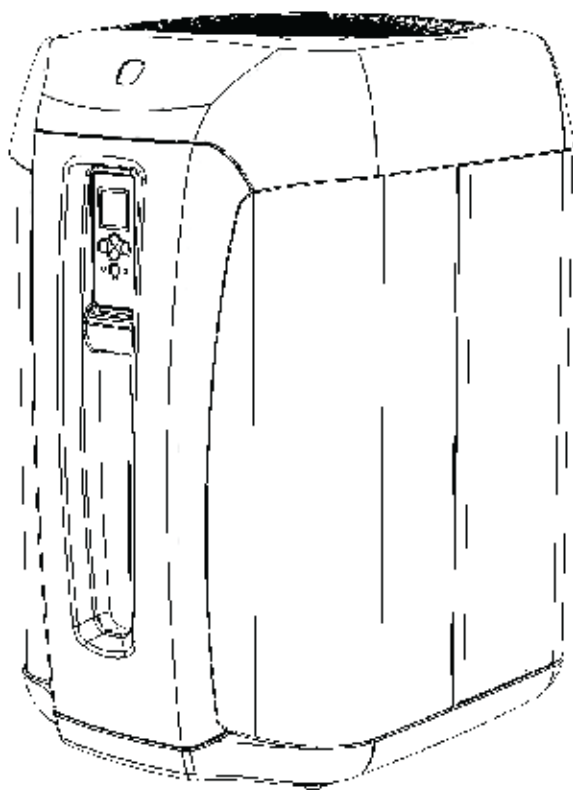

Instructions for installation and use  
English

EN



## Rainbow Pool Products

PO Box 2388, Mansfield Qld 4122

Telephone STD 61-7-3849 5385

Facsimile STD 61-7-3849 5384

Email: [info@rainbowpoolproducts.com.au](mailto:info@rainbowpoolproducts.com.au)

Web: [www.rainbowpoolproducts.com.au](http://www.rainbowpoolproducts.com.au)

More documents on:  
[www.zodiac-poolcare.com](http://www.zodiac-poolcare.com)

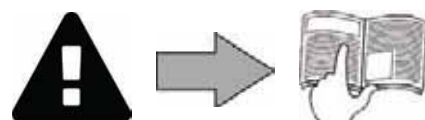

## WARNINGS

- Failure to respect the warnings may cause serious damage to the pool equipment or cause serious injury, even death.
- The appliance is intended for a specific pool use and must not be used for any use other than that for which it was designed.
- It is important that the equipment is operated by competent and qualified (both physically and mentally) people who have previously received the instructions for use. All persons not meeting these criteria must not approach the appliance in order to avoid exposure to dangerous elements.
- Keep the appliance out of the reach of children.
- The device must be installed by a qualified technician according to the manufacturer's instructions and in compliance with local regulations. The installer is responsible for installation of the equipment and for compliance with national installation regulations. Under no circumstances can the manufacturer be held liable in the event of failure to comply with applicable local standards.
- Incorrect installation and/or use may cause serious damage to property or serious injuries (possibly causing death).
- All equipment, even postage and packing paid, travels at the risks and perils of the recipient. The consignee shall make reservations in writing on the carrier's bill of lading if damage is detected, caused during transport (confirmation to be sent to the carrier within 48 hours by registered mail with acknowledgement of receipt). In the event of a device containing coolant that has been turned on its side, mention your reservations in writing to the carrier.
- If the appliance suffers a malfunction, do not try to repair the appliance yourself, contact a qualified technician.
- Refer to the warranty conditions for details of the permitted water balance values for operating the appliance.
- Eliminating or shunting one of the safety devices automatically voids the warranty, as does the replacement of parts using parts not manufactured by ourselves.
- Do not spray insecticide or any other chemical (inflammable or non-inflammable) in the direction of the appliance, as this may damage the body and cause a fire.
- Heat pump, filtration pump and filter appliances are compatible with all types of water treatment.
- For heat pump appliances or dehumidifiers, do not touch the fan or insert a rod or your fingers through the grating when the appliance is in operation. The fan rotates at high speed and may cause injuries or even death.
- The electrical supply to the appliance must be protected by a dedicated 30 mA differential residual current protection device, complying with the standards and regulations in force in the country where it is installed.
- Means for disconnection from the supply mains having a contact separation in all poles that provide full disconnection under overvoltage category III, must be incorporated in the fixed wiring in accordance with the wiring rules.
- Before carrying out any operations, check that:
  - The voltage indicated on the maker's plate of the appliance corresponds to the mains voltage,
  - The power grid is adapted to the power requirements of the appliance, and is grounded.
  - The plug (where applicable) is suitable for the socket.
- In the event of abnormal function or the release of odours from the appliance, turn it off immediately, unplug it from its power supply and contact a professional.
- Before any intervention on the appliance, ensure that the latter is switched off and disconnected from the power supply, in addition to any other equipment connected to the appliance, and that the heating priority (where applicable) is deactivated.
- Do not disconnect and reconnect the appliance to the power supply when in operation.
- Do not pull on the power cord to disconnect it from the power supply.
- Do not handle the electrical elements with wet hands.
- Clean the terminal board or the power supply socket before connection.
- For any component or sub-assembly containing a battery: do not recharge or dismantle the battery, or throw it into a fire. Do not expose it to high temperatures or direct sunlight.
- In stormy weather, unplug the appliance to prevent it from suffering lightning damage.
- Do not immerse the appliance in water (with the exception of cleaners) or mud.
- Do not discharge R410A or R407C fluid into the atmosphere. These are fluorinated greenhouse effect gases, covered by the Kyoto Protocol, with a Global Warming Potential (GWP) = 1975 for R410A or 1653 for R407C - (Directive EC 842/2006).
- According to French decree No. 2007-737, if the appliance has more than 2 kg of refrigerant gas (refer to manufacturer specifications), the cooling circuit must be checked for leakage at least once a year. This operation must be carried out by a certified cooling appliance specialist.

EN



### Additional recommendations in relation to the Pressure Equipment Directive (PED-97/23/EC)

#### Installation and maintenance

The unit may not be installed close to combustible materials, or the air duct inlet of an adjacent building.

With some devices, it is essential to fit protection grids if the unit is installed in an area with uncontrolled access.

During installation, troubleshooting and maintenance, pipes may not be used as steps: the pipe could break under the weight, spilling refrigerant and possibly causing serious burns.

When servicing the appliance, the composition and state of heat carrying fluid must be checked, as well as the absence of any refrigerant.

During the annual unit sealing test in accordance with applicable legislation, the high and low pressure switches must be checked to ensure that they are securely fastened to the coolant circuit and that they cut-off the electrical circuit when tripped.

During maintenance work, ensure there are no traces of corrosion or oil around cooling components.

Before beginning work on the cooling circuit, stop the device and wait for a few minutes before fitting the temperature and pressure sensors. Some elements such as the compressor and piping may reach temperatures in excess of 100°C and high pressures with the consequent risk of severe scalding.

#### Troubleshooting

All soldering work must be carried out by a someone qualified to do so.

Replacement pipes must always be made of copper in compliance with standard NF EN 12735-1.

Leak detection, pressure test:

- never use oxygen or dry air, risk of fire or explosion,
- use dry nitrogen or the mixture of nitrogen and refrigerant indicated on the information plate,
- the test pressure for both the high and low pressure circuits must not exceed 42 bar (for R410A), 20 bar and 15 bar (for R407C) in the case the device is equipped with the optional pressure gauge.

The high pressure circuit pipes are made of copper and have a diameter equal to or greater than 1 1/8". A certificate as indicated in §2.1 in compliance with standard NF EN 10204 will be requested from the supplier and filed in the facility's technical documentation.

Technical data relative to the safety requirements of the various applicable directives must be indicated on the information plate. All this information must be recorded in the unit's installation manual, which must be kept in the technical file of the unit: model, code, serial number, maximum and minimum OT, OP, year of manufacture, EC label, manufacturer's address, refrigerant and weight, electrical parameters, thermo-dynamic and acoustic performances

#### Recycling

This symbol means that your appliance must not be thrown into a normal bin. It will be selectively collected for the purpose of reuse, recycling or transformation. Any substances it may contain which are potentially dangerous to the environment shall be eliminated or neutralised.



Request information on recycling procedures from your retailer.



- Before you do anything with the device, it is vital that you read this installation and user manual, as well as the "warnings and warranty" booklet delivered with the device. Failure to do so may result in material damage or serious or fatal injury and will invalidate the warranty.
- Keep and pass on these documents for later consultation during the device's life time.
- It is prohibited to distribute or modify this document in any way without authorisation from Zodiac®.
- Zodiac® is constantly developing its products to improve their quality; therefore, the information contained in this document may be modified without notice.

## CONTENTS



### 1 Installation

3

1.1 | Selecting the location

3

1.2 | Hydraulic connections

4

1.3 | Electricity supply connections

5

1.4 | Option connections

6



### 2 Use

7

2.1 | Operating principle

7

2.2 | User interface presentation

7

2.3 | Operating

8

2.4 | User functions

9

2.5 | Presentation of the menu

10



### 3 Maintenance

11

3.1 | Wintering

11

3.2 | Maintenance

11



### 4 Troubleshooting

12

4.1 | Device behaviour

12

4.2 | Error code display

13

4.3 | Additional menus

14

4.4 | Wiring diagrams

15



### 5 Specifications

17

5.1 | Description

17

5.2 | Technical specifications

18

5.3 | Dimensions and marking

18



#### **Tip: to make it easier to contact your reseller**

- Write down your reseller's contact details to help you find them more easily and fill in the "product" information on the back of the manual; your reseller will ask you for this information.



# 1 Installation

## ➤ 1.1 | Selecting the location



- The device must be installed at a minimum distance from the pool's surrounding edge. This distance is determined by the electrical standards which apply in the installation country.
- Do not lift the appliance using the casing, handle it from the base.

- For outdoor installation, provide free space around it (see § "1.2 | Hydraulic connections").
- For indoor installation, the device must be equipped with the plant room kit.
- Place the device on its anti-vibration studs (integrated under its base, height adjustable) on a stable, solid and level surface,
- This surface must be able to bear the weight of the device (in particular in the case of installation on a roof, a balcony or any other support).

The device must not be installed:

- With the blowing towards a permanent or temporary obstacle (awning, brushwood, etc.) less than 5 metres away,
- Within range of water or mud jets, sprays or run-off (take the effect of the wind into account),
- Near a heat source or flammable gas,
- Near high frequency equipment,
- In a location where it would be subject to snow build-up,
- In a location where it might be flooded by the condensation produced by the device when operating.

EN

### **Tip: reduce any noise annoyance from your heat pump**



- Do not install it under or towards a window.
- Do not tilt it towards your neighbours.
- Install it in a clear space (the sound waves are reflected on surfaces).
- Install an acoustic screen around the heat pump, respecting the distances.
- Install 50cm of flexible PVC pipe at the heat pump water input and output (stops vibrations).
- Increase the filtration time by 50% and activate "Eco Silence" mode. The heat pump will run for longer with less power, but much more quietly and with an improved COP (energy savings). Only use the "Eco Silence" mode to maintain the desired temperature.



## **Rainbow Pool Products**

PO Box 2388, Mansfield Qld 4122

Telephone STD 61-7-3849 5385

Facsimile STD 61-7-3849 5384

Email: [info@rainbowpoolproducts.com.au](mailto:info@rainbowpoolproducts.com.au)

Web: [www.rainbowpoolproducts.com.au](http://www.rainbowpoolproducts.com.au)

## ➤ 1.2 | Hydraulic connections

- The device will be connected with a  $\varnothing 50$  PVC pipe, using the half union connectors supplied (see § “5.1 | Description”), to the pool's filtration circuit, after the filter and before the water treatment.
- Respect the direction of hydraulic connection.
- A by-pass must be installed to make it easier to work on the device.

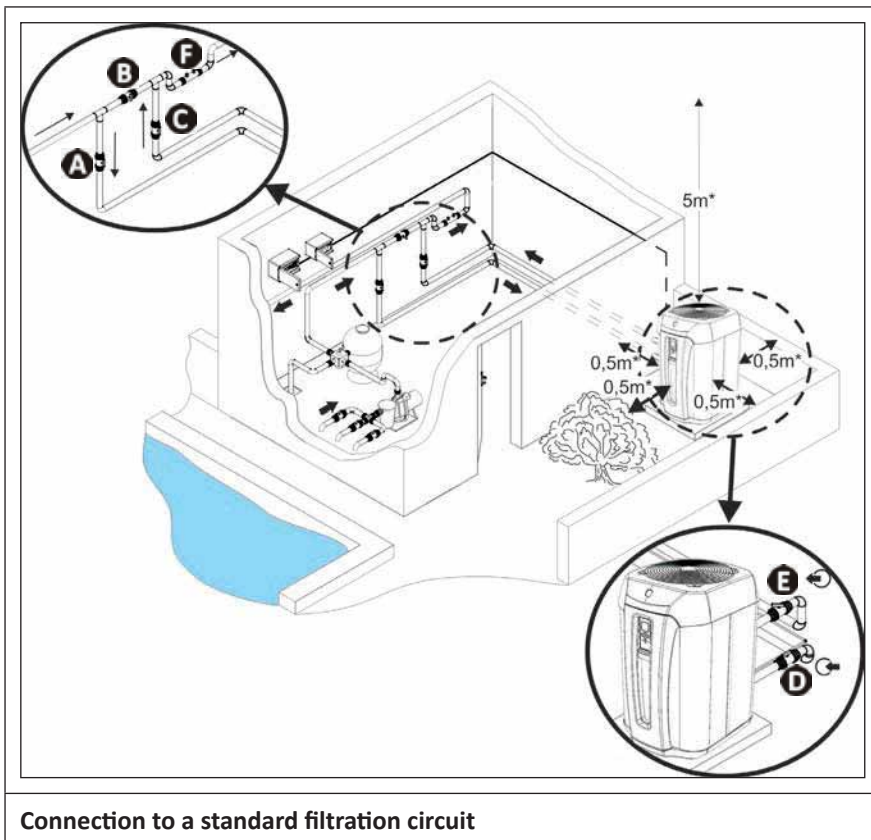

- To evacuate the condensation, fit a  $\varnothing 18$  pipe inside the grooved elbow to be mounted under the device's base.

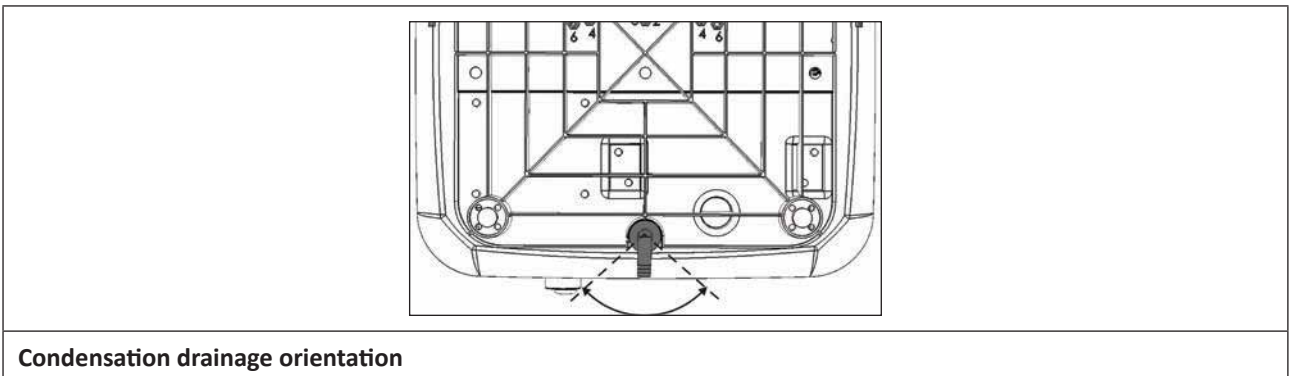

### **Tip: condensation drainage**

Caution, several litres of water must be drained from your device each day. We strongly recommend connecting the drainage to the sewers. We also recommend tilting the device slightly backwards (using the adjustable studs) for better condensation drainage.

### 1.3 | Electricity supply connections

- Do not disconnect the electricity supply when the device is running. If the electric power supply is interrupted, wait a minute before restoring the power.
- Means for disconnection from the supply mains having a contact separation in all poles that provide full disconnection under overvoltage category III, must be incorporated in the fixed wiring in accordance with the wiring rules.
- **Incorrectly tightened terminals may cause the terminal unit to heat up and invalidate the warranty.**
- **Before any work inside the device, you must cut the electricity supply as there is a risk of electric shock which may cause material damage, serious injury or even death.**
- **Only a qualified and experienced technician is authorised to carry out cabling in the equipment or to replace the supply cable.**

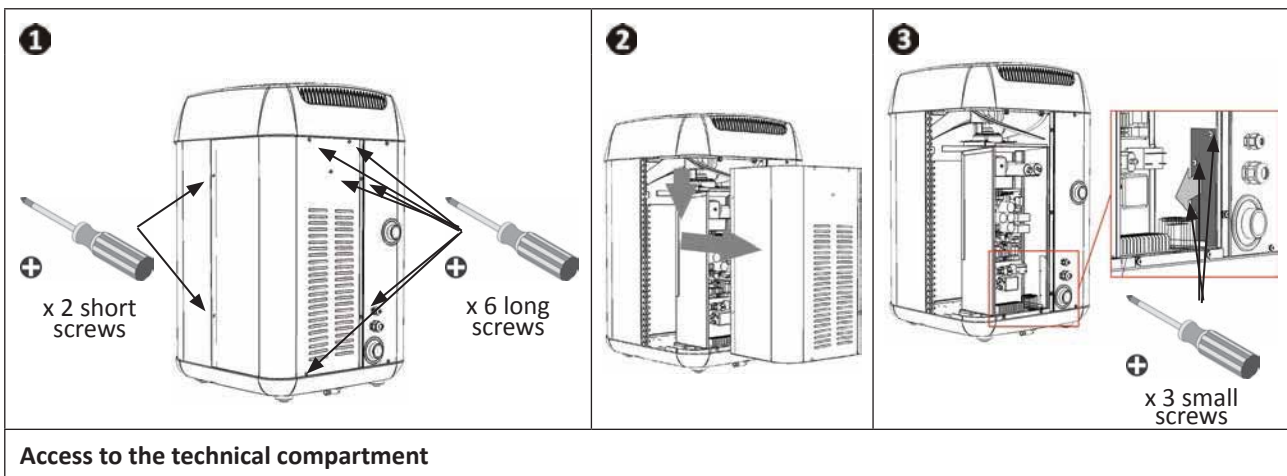

#### Access to the technical compartment

- The heat pump's electrical supply must be provided through a protection and circuit breaking device (not supplied) complying with the standards and regulations in force in the country where it is installed,
- The device is provided for connection to a general power supply with a TT and TN.S neutral regime.
- Electrical protection: by circuit breaker (D curve) (for calibre, see § "5.2 | Technical specifications"), with a 30 mA dedicated differential circuit breaker (circuit breaker or switch).
- Additional protection may be required during installation to guarantee the II overvoltage category.
- The electricity supply must correspond to the voltage indicated on the device's information plate.
- The electricity supply cable must be insulated against any cutting or hot elements that may damage or crush it.
- The equipment must be connected to an earth socket.
- The electrical connection lines must be fixed.
- Use the gland to pass the supply cable into the device.
- Used the supply cable (H07RN-F type) adapted for outdoor or buried use (or run the cable into a protection duct) with an external diameter of between 9 and 18mm.
- We recommend burying the cable at a depth of 50 cl (85 cm under a road or path) in an electrical duct (red ribbed).
- If this buried cable meets another cable or pipe (gas, water, etc.), there must be more than 20 cm between them.
- Connect the supply cable to the connection terminal unit inside the device. On three phase models, there is no live order to be respected.

	<p>L: live N: neutral ⊕: earth</p>		<p>L1-L2-L3: live N: neutral ⊕: earth</p>
<p>Single phase terminal unit</p>		<p>Three-phase terminal unit</p>	



## 1.4 | Option connections

### Connecting the "Heating priority", "On/off command" and "Alarm" options:



- Any incorrect connection to terminals 1 to 12 may damage the device and cancel its warranty.
- Under no circumstances should the filtration pump motor be supplied via terminals 11-12.
- When intervening on terminals 1 to 12, there is a risk of electrical return current, injuries, material damage and death.
- Use cables with a section of at least  $2 \times 0.75 \text{mm}^2$ , H07RN-F type and with a diameter between 8 and 13mm.
- Use the gland to pass the cables into the device. The cables used for the options and the supply cable must be kept separate (risk of interference) using a collar inside the device just after the glands.

#### 1.4.1 "Remote control" option

- This option enables the device's control panel to be transferred to enable the device to be controlled by remote. To do so, use the remote control kit available as an accessory (plastic cover + metal support + RJ11/RJ45 extension cable).
- For the connection, consult the manual supplied with the kit.

#### 1.4.2 "Heating priority" option

- This function helps to keep the water temperature constant by checking the water temperature at regular time intervals (minimum 5 minute cycle every 60 minutes) by filtration pump control. The filtration is kept operating if the pool temperature is below the temperature requested.
- For the connection, connect the filtration timer to terminals 11 and 12 (dry contact, no polarity, maximum intensity 8A).
- The "Heating priority" function is activated by default; to deactivate it, set the P50 parameter to 0 (see § "4.3 | Additional menus")

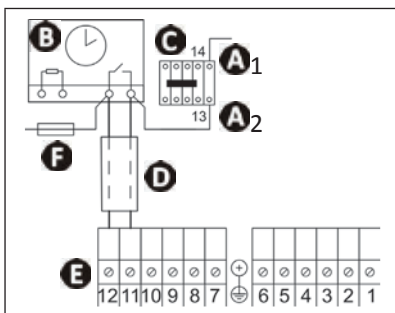

- **A1- A2** : power for the filtration pump power contactor coil
- **B**: filtration timer
- **C**: power contactor (tripolar or bipolar) for the filtration system pump motor
- **D**: separate cable for the "heating priority" function
- **E**: heat pump terminal unit
- **F**: fuse

#### 1.4.3 Remote "on/off" control option

- This option enables the "on/off" button function to be transferred via a switch installed by remote.
- For the connection, remove the shunt between terminals 9-10 and connect the switch cable in place (potential free contact, no polarity, 220-240V ~ 50Hz).

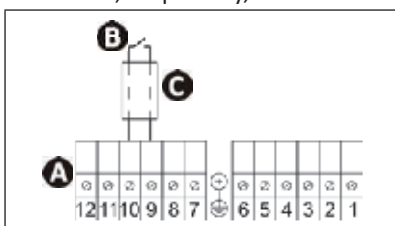

- **A**: heat pump terminal unit
- **B**: remote "on/off" switch
- **C**: separate connection cable

#### 1.4.4 "Alarm" option

- This option enables a relay to be connected to the alarm contact to indicate a fault by remote.
- For the connection, connect the cables to terminals 1 and 2 (220-240V 2A maximum when the alarm is active, dry contact).

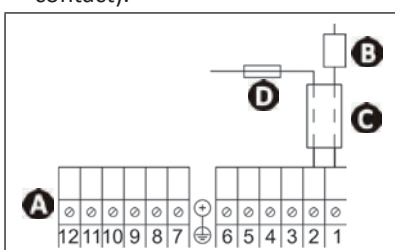

- **A**: heat pump terminal unit
- **B**: alarm contact relay
- **C**: separate connection cable
- **D**: fuse



## 2 Use

### 2.1 | Operating principle

Your heat pump uses the calories (heat) in the air to heat up your pool's water. The process to heat your pool's water to the temperature you want may take a few days as it depends on the weather conditions, your heat pump's power and the difference between the water temperature and the temperature you want.

The heat pump is ideal for maintaining temperature.

The warmer and damper the air, the better your heat pump will perform. The outdoor parameters for optimum operation are an air temperature of 27°C, a water temperature of 27°C and 80% hygrometry.

**Tip: improve your pool's temperature rise and maintenance**



- Anticipate the commissioning of your pool far enough in advance before you use it.
- For the temperature rise, set the water circulation continuous (24/24) in "Boost" mode.
- To maintain the temperature throughout the season, run "automatic" circulation for at least 12 hours/day (the longer this time the longer the appliance will have enough operating range to heat up) in "Smart" or "Eco Silence" mode.
- Cover the basin with a sheet (bubble canopy, canvas, etc.) to prevent heat loss.
- Take advantage of a period with mild outdoor temperatures (on average > 10°C at night); it will be even more effective if it runs during the warmest hours of the day.
- Keep the evaporator clean.
- Set the temperature you want and let the heat pump run.
- Connect the "Heating priority"; the filtration pump and heat pump operating time will be set according to requirements.

EN

### 2.2 | User interface presentation

	"On/off button" (press and hold for 3 seconds)
	Menu access selection button
	Back/exit button
	Value setting button
"Power" light	Fixed = device powered up
"Alert" light	Flashing = alert message on the screen or operating fault

Screen type	Display	Content
Splash screen (4 seconds)	<pre> ZODIAC ZS 500  Software Version A1 : VMA-06 A2 : VPA-07           </pre>	Model  Electronic board software versions A1 = regulation board A2 = display board (No. given for information purposes)
Home screen	<pre> THURSDAY 09:11 Current Mode: SMART V1 Setpoint: 29.5°C Inlet water T°C: 23.5°C  Unit Status: Heating           </pre>	Date Operating mode Temperature set point Water intake temperature Heat pump status



## ➤ 2.3 | Operating

- Check that there are no tools or other foreign objects in the machine.
- The panel that provides access to the technical section must be put in place.
- Set the valves as follows: valve B wide open, valves A, C, D and E closed.

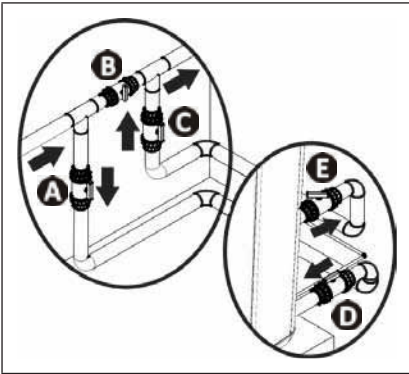

- A**: water entry valve
- B**: by-pass valve
- C**: water exit valve
- D**: water entry adjustment valve (optional)
- E**: water exit adjustment valve (optional)



- **An incorrect by-pass setting may cause the heat pump to malfunction.**



- Check that the hydraulic corrections are correctly tightened and that there are no leaks.
- Check that the device is fully stable.
- Set the water circulation running.
- Close valve B gradually so that the filter pressure is increased by 150g (0.150 bars).
- Open valves A, C and D fully then valve E by half (the air which has built up in the heat pump condenser and the filtration circuit will bleed out). If valves D and E are not present, open valve A wide and close valve C by half.
- Connect the power supply to the heat pump.
- If the heat pump is on standby, press  for 3 seconds; the splash screen appears for 4 seconds then the home screen is displayed. A 2-minute timer will start.
- Set the temperature you want ("setpoint" temperature).

After the start-up steps for your heat pump:

- Shut down the water circulation temporarily (by stopping the filtration or closing valve A or C) to check that you device stops after a few seconds (via the activation of the flow rate controller).
- Reduce the setpoint temperature to below the water temperature to check that the heat pump stops operating.
- Switch off the heat pump by pressing and holding  for 3 seconds and check that it stops.

## 2.4 | User functions

### 2.4.1 Adjusting the temperature set point:

- Press  to increase the temperature by 0.5 °C,
- Press  to reduce the temperature by 0.5 °C.

The heat pump stops automatically when the pool reaches the required temperature.

### 2.4.2 Using the different operating modes

This heat pump has three operating modes:

		Operating mode		
Operating speed Operating power	V1 100%		Smart	Boost
	V2 75%	Eco Silence		
	V3 50%			
Objective	Most economical and quietest operation		Smart temperature control, no intervention is needed to change the operating mode	To increase to the desired temperature quickly.
	Adapts the power automatically to requirements.			
When to use	Maintaining the temperature			Starting the pool
	Low heating requirements and silent operation desired	No desire to need to intervene on the device		

EN

### 2.4.3 Locking/unlocking the keyboard

Press and hold  and  for 3 seconds:



## Rainbow Pool Products

PO Box 2388, Mansfield Qld 4122

Telephone STD 61-7-3849 5385

Facsimile STD 61-7-3849 5384

Email: [info@rainbowpoolproducts.com.au](mailto:info@rainbowpoolproducts.com.au)

Web: [www.rainbowpoolproducts.com.au](http://www.rainbowpoolproducts.com.au)



## 2.5 I Presentation of the menu

```

THURSDAY 09H11
MENU

Modes Selection
Report
Waterflow set
Parameters
Time Setting
Languages
Contraste
    
```

To access the menu, press .

To browse the menus and modify the values, press  or .

To validate a selection, press .

To go back in the menus, press .

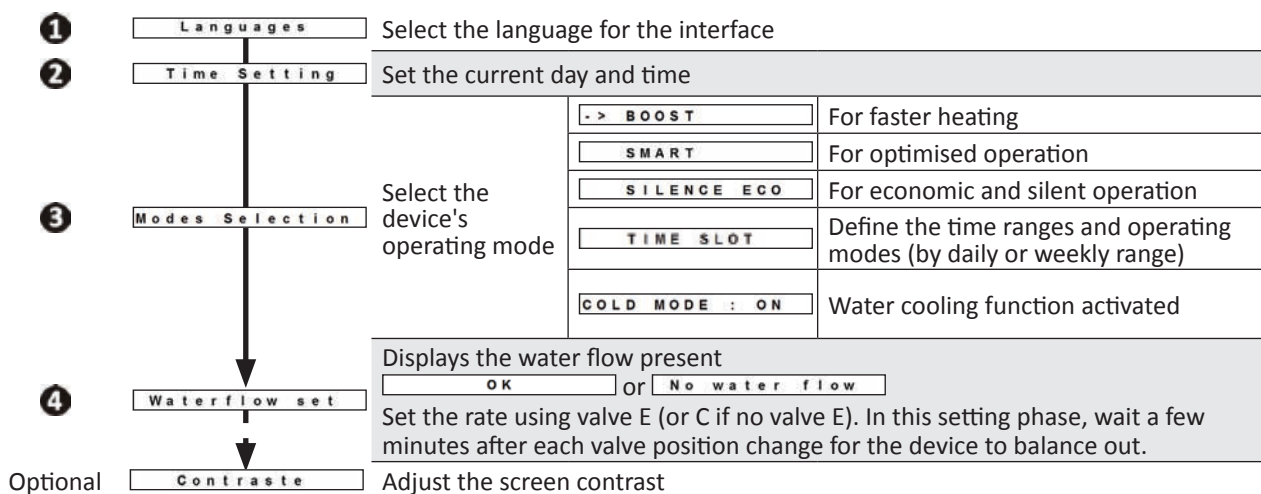

### Tip: programme your time windows properly

If you want to program the device over the 24 hours of a day, start the first time slot at 00:00 and end the last at 24:00.



```

Time Slot
WEEK-END

Start End
SILENCE 00H-08H
BOOST 08H-12H
SMART 12H-20H
SILENCE 20H-24H

Clear
    
```

The heat pump will not work in time windows that are not entered.



## 3 Maintenance

### 3.1 I Wintering



- **Wintering is vital to prevent the condenser breaking due to freezing. This is not covered by the warranty.**
- **To avoid damaging the equipment with condensation, do not fully cover it; a wintering cover is provided.**

- Set the regulator to "standby" mode by pressing and holding  for 3 seconds and disconnect the power supply,
- Open valve B,
- Close valves A and C and open valves D and E (if present),
- Make sure that there is no water circulating in the heat pump,
- Drain the water from the condenser (risk of freezing) by unscrewing the two water input and output connectors on the back of the heat pump,
- In the case of full wintering for the pool (complete shutdown of the filtration system, bleed the filtration circuit or even pool drainage): tighten the two connectors by one turn to prevent any foreign bodies from getting into the condenser,
- In the case of wintering for the heat pump only (shutdown of the heating only, the filtration keeps running): to not tighten the connectors but add 2 caps (provided) on the condenser's water inputs and outputs.
- We recommend that you put the aired wintering micro cover (provided) on the heat pump.

EN

### 3.2 I Maintenance



- **Do not disconnect the electricity supply when the device is running.**
- **If the electric power supply is interrupted, wait a minute before restoring the power.**
- **It is recommended that the device be general serviced at least on a yearly basis to ensure proper operation, maintain performance levels and prevent some potential failures. These operations are carried out at the user's expense, by a technician.**

#### 3.2.1 User maintenance

- Make sure that the filter is not blocked by any foreign bodies.
- Clean the evaporator (for location see § "5.3 I Dimensions and marking") using a soft brush and a fresh water spray (disconnect the power cable); do not fold over the metal wings, then clean the condensation drainage pipe to remove any impurities that may be blocking it.
- Make sure that the electrical unit's ventilation grid is clean.
- Do not use a high pressure jet. Do not spray with rain water, salt water or water which is full of minerals.
- Clean the outside of the device; do not use any solvent-based products. We can provide you with a specific cleaning kit as an accessory: the PAC NET, see § "5.1 I Description".

#### 3.2.2 Maintenance to be carried out by a qualified technician

- Check that the regulation is operating correctly connected.
- Check that the condensation flows correctly when the device is operating.
- Check the safety mechanisms.
- Check the connection of the metal masses to the earth.
- Check that the electrical cables are correctly tightened and connected and that the electrical unit is clean.







## 4 Troubleshooting



- Before you contact your reseller, please carry out these few simple checks using the following tables if a problem occurs.
- If the problem continues contact your reseller.
-  : Actions reserved for a qualified technician







### 4.1 I Device behaviour

The device does not start heating straight away	<ul style="list-style-type: none"> <li>• On start-up, the device remains "paused" for 30 seconds before it starts operating.</li> <li>• When the setpoint temperature is reached, the heat pump stops heating: the water temperature is higher than or equal to the setpoint temperature.</li> <li>• When the water flow rate is zero or is not enough, the heat pump stops: check that the water is circulating correctly in the heat pump (see § "2.5 I Presentation of the menu") and that the hydraulic connections are correct.</li> <li>• The heat pump stops when the outdoor temperature falls below -12 °C.</li> <li>• It may be that the heat pump has detected an operating fault (see § "4.2 I Error code display").</li> <li>• If you have checked these points and the problem persists: contact your reseller.</li> </ul>
The device is draining water	<ul style="list-style-type: none"> <li>• Often called condensation. This water is the moisture contained in the air which condenses on contact with certain cold mechanisms in the heat pump, especially on the evaporator. The more damp the air, the more condensation your heat pump will produce (your device may drain several litres of water per day). This water is retrieved by the base of the heat pump and drained through the holes.</li> <li>• To check that the water is not coming from a leak in the pool circuit on the heat pump, shut down the heat pump and run the filtration pump for the water to circulate in the heat pump. If the water continues to flow through the condensation drains, there is a water leak in the heat pump; contact your reseller.</li> </ul>
The evaporator is iced over	<ul style="list-style-type: none"> <li>• Your heat pump will soon switch to its defrost cycle to melt the ice.</li> <li>• If your heat pump cannot manage to deice its evaporator, it will stop itself; this means that the outdoor temperature is too low (below -12 °C).</li> </ul>
The device is "smoking"	<ul style="list-style-type: none"> <li>• This may occur when it is in a defrost cycle and the water is converted to gas.</li> <li>• If your heat pump is not in its defrost cycle, this is not normal. Switch off and disconnect the heat pump immediately and contact your reseller.</li> </ul>
The device is not working	<ul style="list-style-type: none"> <li>•  If there is no display, check the supply voltage and the F1 fuse.</li> <li>• When the setpoint temperature is reached, the heat pump stops heating: the water temperature is higher than or equal to the setpoint temperature.</li> <li>• When the water flow rate is zero or is not enough, the heat pump stops: check that the water is circulating correctly in the heat pump (see § "2.5 I Presentation of the menu").</li> <li>• The heat pump stops when the outdoor temperature falls below -12 °C.</li> <li>• It may be that the heat pump has detected an operating fault (see § "4.2 I Error code display").</li> <li>• The device is in an empty time range. Deactivate the "time range" mode to launch manual operation or modify the time range programming.</li> </ul>
The device is working but the water temperature does not increase	<ul style="list-style-type: none"> <li>• The operating mode is not powerful enough (device in "Eco Silence" or "Smart" mode). Switch to "Boost" mode and set the filtration to 24/24 manual while the temperature rises.</li> <li>• It may be that the heat pump has detected an operating fault (see § "4.2 I Error code display").</li> <li>• Check that the automatic filling valve is not stuck in open position; this will keep supplying cold water into the pool and will prevent the temperature from rising.</li> <li>• There is too much heat loss as the air is cool. Install a heat insulated cover on your pool.</li> <li>• The heat pump is unable to capture enough calories as its evaporator is clogged with dirt. Clean it to restore its performances (see § "3.2 I Maintenance").</li> <li>• Check that the external environment is not hindering the heat pump (see § "1 Installation").</li> <li>•  Check that the heat pump is the right size for this pool and its environment.</li> </ul>
The ventilator is running but the compressor stops from time to time with no error message	<ul style="list-style-type: none"> <li>• If the outdoor temperature is low, the heat pump will perform defrost cycles.</li> <li>• The heat pump is unable to capture enough calories as its evaporator is clogged with dirt. Clean it to restore its performances (see § "3.2 I Maintenance").</li> </ul>
The device trips the circuit breaker	<ul style="list-style-type: none"> <li>•  Check that the circuit breaker is correctly dimensioned and that the cable section used is the right one (see § "5.2 I Technical specifications").</li> <li>•  The supply voltage is too low; contact your electricity supplier.</li> </ul>

## 4.2 | Error code display



Display	Possible causes	Solutions	Resetting
<b>Error 01</b> Communication fault between the regulation board and the display board	Bad connection between the A1 and A2 boards	 Check the RJ11 and RJ45 connectors on the link cable between the boards	Automatic (if fewer than 4 faults per hour) or press 
	Board power supply fault	 Check the boards' power supply	
	Faulty boards	 Replace the boards	Automatic
<b>Error 02</b> Overheating on the electronic board	Machine's rear panel slots blocked	Clean the rear panel. If problem persists, call an approved technician	Automatic (if fewer than 4 faults per hour) or press 
	Ventilator operating incorrectly	 Replace the ventilator motor	
<b>Error 03</b> Automatic protection against electrical network instabilities	Electrical network overvoltage or interruption or drop in the network voltage	 Check the quality of the electrical network	Automatic (if fewer than 4 faults per hour) or press 
	Incorrect earthing	 Check that the earth cables are correctly connected	
	A1 board operating incorrectly	 Replace the A1 board	
<b>Error 05</b> Error on the ventilator motor	Ventilator motor disconnected	 Check the ventilator motor connector. If problem persists, call an approved technician	Automatic (if fewer than 4 faults per hour) or press 
	Ventilator motor damaged	 Replace the ventilator motor	
<b>Error 06</b> Compressor supply overheating	Machine's rear panel slots blocked	Clean the rear panel. If problem persists, call an approved technician	Automatic (if fewer than 4 faults per hour) or press 
	Ventilator operating incorrectly	 Replace the ventilator motor	
<b>Error 07</b> Compressor supply overintensity	Electrical supply over or undervoltage	 Check the electrical supply voltage (maximum 240V ±10%)	Automatic (if fewer than 4 faults per hour) or press 
	Compressor operating incorrectly	 Replace the compressor	
	A1 board operating incorrectly	 Replace the A1 board	
	Incorrect connection of the masses to the earth.	 Check that the earth cables are correctly connected	
<b>Error 08</b> Low pressure fault on cooling circuit	Pressure fault in the low pressure circuit (if problem persists after resetting)	Call an approved technician	Automatic (if fewer than 4 faults per hour) or press 
<b>Error 09</b> Cooling circuit high pressure fault	Exchanger clogged with dirt	 Clean the water exchanger	Automatic (if fewer than 4 faults per hour) or press 
	Insufficient water flow	 Increase flow using by-pass, check that the pool filter is not clogged	
	Air and water emulsion passed into the device	 Check the pool's hydraulic circuit	
	Flow controller blocked	 Check the flow controller	
<b>Error 10</b> ST3 sensor fault Defrost sensor	Sensor is faulty or offline (J14 connector)	 Reconnect or change the sensor	Press 
<b>Error 11</b> ST sensor fault air intake sensor	Sensor is faulty or offline (J12 connector)	 Reconnect or change the sensor	Press 





Display	Possible causes	Solutions	Resetting
<b>Error 12</b> ST5 sensor error compressor discharge sensor	Sensor is faulty or offline (J13 connector)	 Reconnect or change the sensor	Press 
<b>Error 13</b> ST4 sensor fault fluid line sensor	Sensor is faulty or offline (J16 connector)	 Reconnect or change the sensor	Press 
<b>Error 14</b> ST1 sensor fault water intake sensor	Sensor is faulty or offline (J46 connector)	 Reconnect or change the sensor	Press 

### 4.3 | Additional menus

To access the menu, press .

To browse the menus and modify the values, press  or .

To validate a selection, press .

To go back in the menus, press .

<b>Report</b>	<b>Sensor Value</b>	ST1 : 21.1 °C	Water temperature on intake
		ST2 : 20.8 °C	Air temperature
		ST3 : 21.1 °C	Defrost sensor
		ST4 : 20.8 °C	Fluid line sensor
		ST5 : 21.4 °C	Compressor discharge temperature
		Compressor : 0%	Compressor operating speed
	<b>Speed Value</b>	Ventilator : 0%	Ventilator operating speed
	Open EEV : 100%	Opening of electronic valve	
	<b>Error List</b>	(only accessible to professionals)	
<b>Parameters</b>	<b>Level 1</b>	P01 : 28.0 °C	Temperature set point
		P04 : 2.0 °C	Hysteresis to switch to cooling mode in relation to the setpoint
		P09 : 0.0 °C	Calibration of the ST1 water intake sensor
		P10 : 0.0 °C	Calibration of the ST2 air intake sensor
		P18 : 0	Cooling mode activation
		P16 : 0 H	Fixed operating hours counter
		P17 : 0 H	Counter with operating hours reset
		P28 : 0	Activation of continuous screen backlighting
		P50 : 3	Activation of heating priority mode
		P52 : 120 MIN	"OFF" operation of the filtration pump (if P50 = 3)
	P53 : 5 MIN	"ON" operation of the filtration pump (if P50 = 3)	
	<b>Level 2</b>	Only accessible to professionals	

Values provided for information purposes, factory settings

## 4.4 | Wiring diagrams

### 4.4.1 ZS500 MD4-MD5-MD8

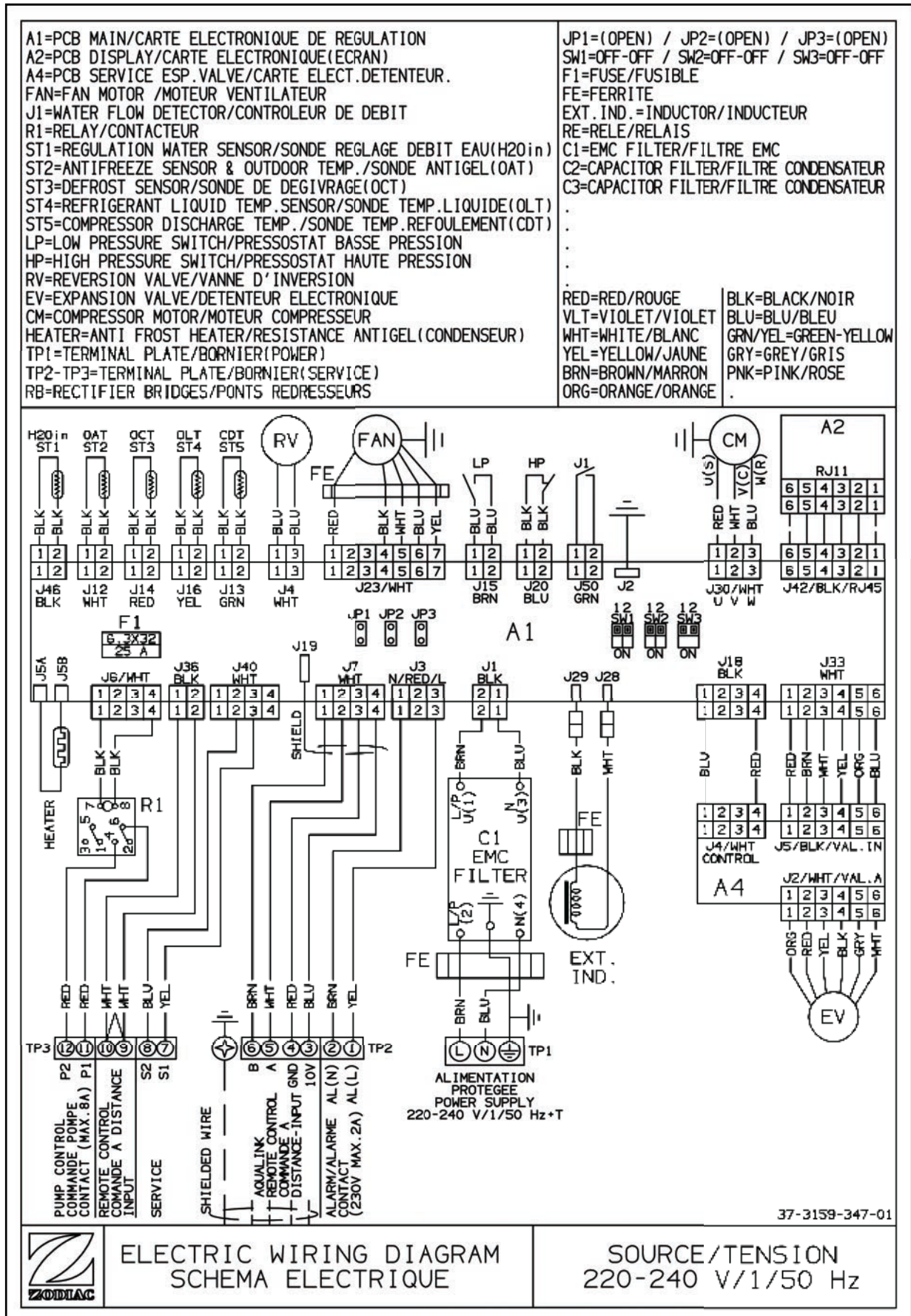

EN







## 5 Specifications

### 5.1 I Description



A		ZS500
B	Ø50 connector to be glued (x2)	✓
C	Condensation evacuation kit (Ø18)	✓
D	Wintering cap (x2)	✓
E	Wintering cover	✓
	Heating priority	✓
F	Kit for remote control	+
G	Plant room kit	+
H	Condensate pan	+
I	PAC NET (cleaning product)	+

✓: supplied

+: available as an accessory

EN

## 5.2 | Technical specifications

ZS500		MD4	MD5	TD5	MD8	TD8
Operating temperature range	air	-12 to 40 °C				
	water	12 to 32 °C				
Voltage		220-240V-50Hz	220-240V-50Hz	380-415V-50Hz	220-240V-50Hz	380-415V-50Hz
Acceptable variation in voltage		± 6 % (during operation)				
Pollution class		I				
Pollution degree		2				
Overvoltage category		III				
Nominal absorbed intensity	A	7.5	10	4.4	15	6
Maximum absorbed intensity	A	10	13.9	6	22	8
Minimum cable section*	mm <sup>2</sup>	3x2.5	3x2.5	5x2.5	3x6	5x2.5
		3G2.5	3G2.5	5G2.5	3G6	5G2.5
Proof pressure	Pa	300,000				
Service pressure	Pa	150,000				
Head loss	mCE	1.5				
Water flow recommended	m <sup>3</sup> /h	4	5	5	6	6

\* Values provided for information purposes for a maximum length of 20 metres (calculation base: NFC15-100), must be checked and adapted to the installation conditions and standards of the installation country.

## 5.3 | Dimensions and marking

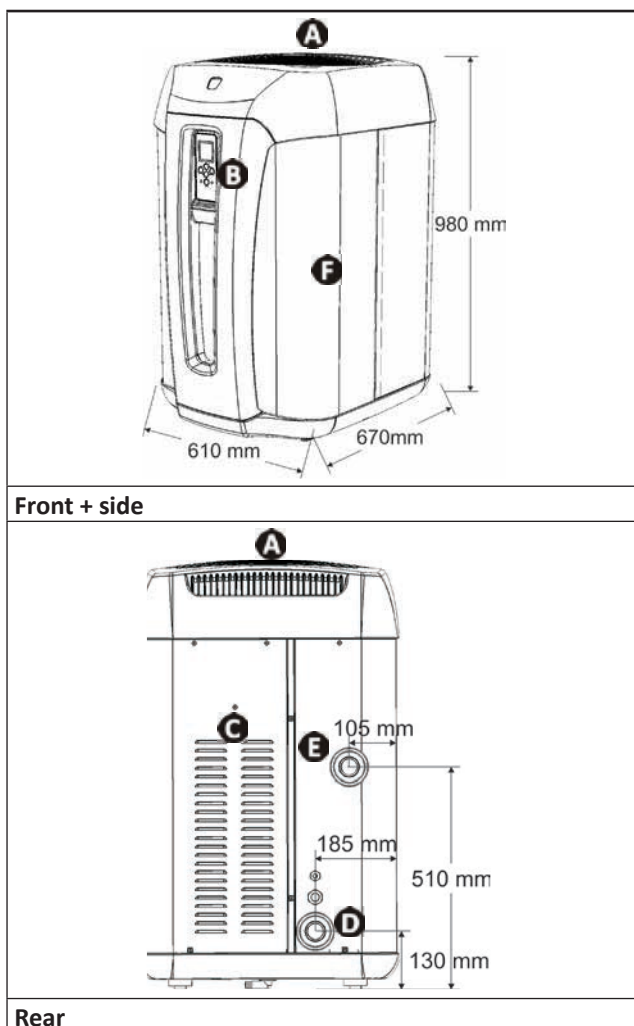

- A**: Grid
- B**: User interface
- C**: Technical access door
- D**: Pool water intake
- E**: Pool water output
- F**: Evaporator

Overall dimensions

Votre revendeur  
*Your retailer*

Modèle appareil  
*Appliance model*

Numéro de série  
*Serial number*



## **Rainbow Pool Products**

PO Box 2388, Mansfield Qld 4122

Telephone STD 61-7-3849 5385

Facsimile STD 61-7-3849 5384

Email: [info@rainbowpoolproducts.com.au](mailto:info@rainbowpoolproducts.com.au)

Web: [www.rainbowpoolproducts.com.au](http://www.rainbowpoolproducts.com.au)